



www.flitetest.com

FT Otter

Designed By: Peter Sripol
Drawing By: Dan Sponholz



SPECIFICATIONS

| DESCRIPTION | | IMPERIAL | METRIC |
|--------------------|-----|-------------------------|------------------------|
| LENGTH | | 32 in | 813 mm |
| CENTER OF GRAVITY | CG | 2.5 in | 64 mm |
| WING SPAN | | 40 in | 1016 mm |
| WING AREA | | 302 in ² | 19.5 dm ² |
| DRY WEIGHT | | 15.1 oz | 428 g |
| ALL UP WEIGHT | AUW | 2.6 oz | 612 g |
| WING LOADING | WL | 10.3 oz/ft ² | 31.4 g/dm ² |
| WING CUBIC LOADING | WCL | 7.1 | |

RECOMMENDED SETTINGS

| | THROW | EXPO |
|----------|-------|------|
| AILERON | 12° | 30% |
| ELEVATOR | 12° | 30% |
| RUDDER | 12° | 30% |



SHEET & TILE KEY

| | | | |
|---|---|---|---|
| 1 | 2 | 3 | 4 |
| 5 | 6 | 7 | 8 |

| | | | |
|----|----|----|----|
| 9 | 10 | 11 | 12 |
| 13 | 14 | 15 | 16 |

| | | | |
|----|----|----|----|
| 17 | 18 | 19 | 20 |
| 21 | 22 | 23 | 24 |

| | | | |
|----|----|---------------|---------------|
| 25 | 26 | 27 | 28 |
| 29 | 30 | 31 | 32 |



DRAWING KEY

FOLD TYPES

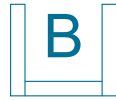

A - FOLD (ABOVE)

B - FOLD (BESIDE)

C - FOLD (COVER)

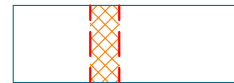
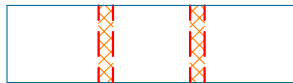
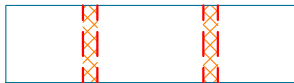

LINE TYPE/COLOR

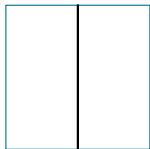

CUT

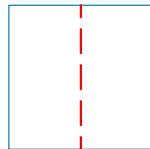

50% SCORE

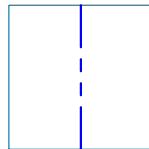

CREASE

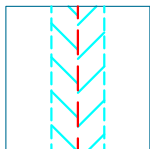

45° DOUBLE
BEVEL

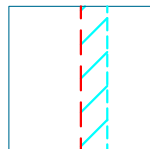

45° SINGLE
BEVEL

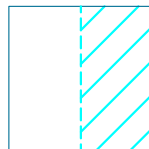

EDGE
BEVEL

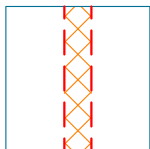

CAVITY

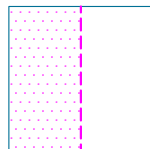

REMOVE
PAPER

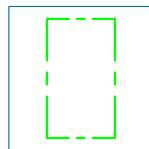

REFERENCE/
OPTIONAL



SYMBOLS

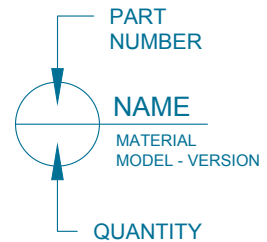

MIRRORED
PART



CENTER
OF
GRAVITY
(CG)

FT Otter

Designed By: Peter Stripol
Drawing By: Dan Sponholz

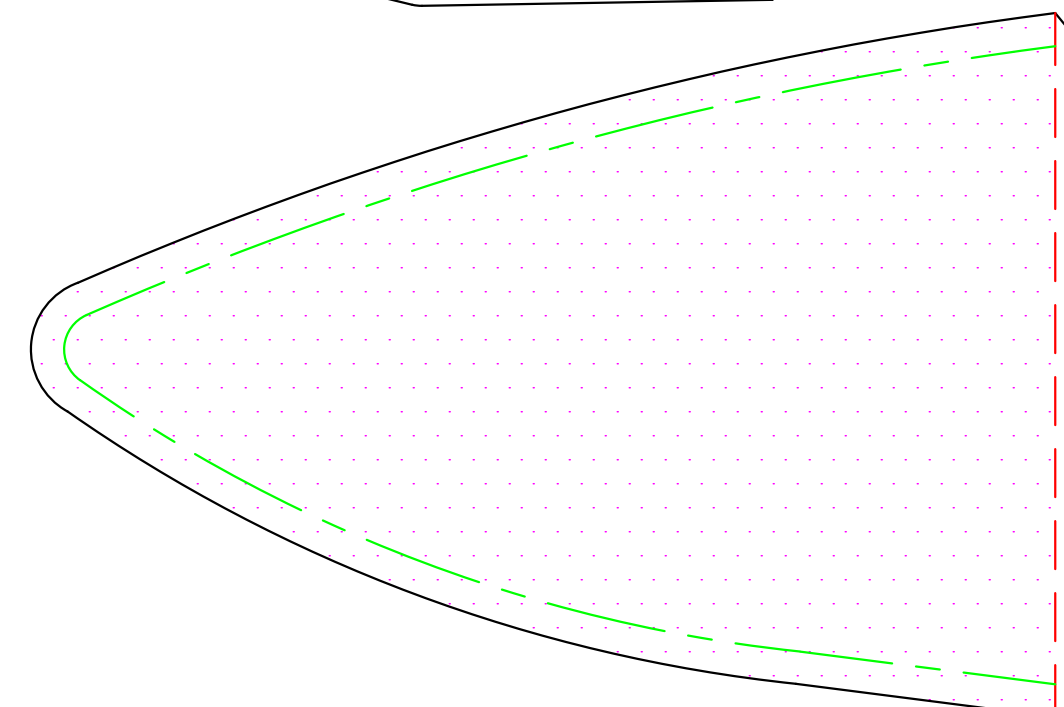
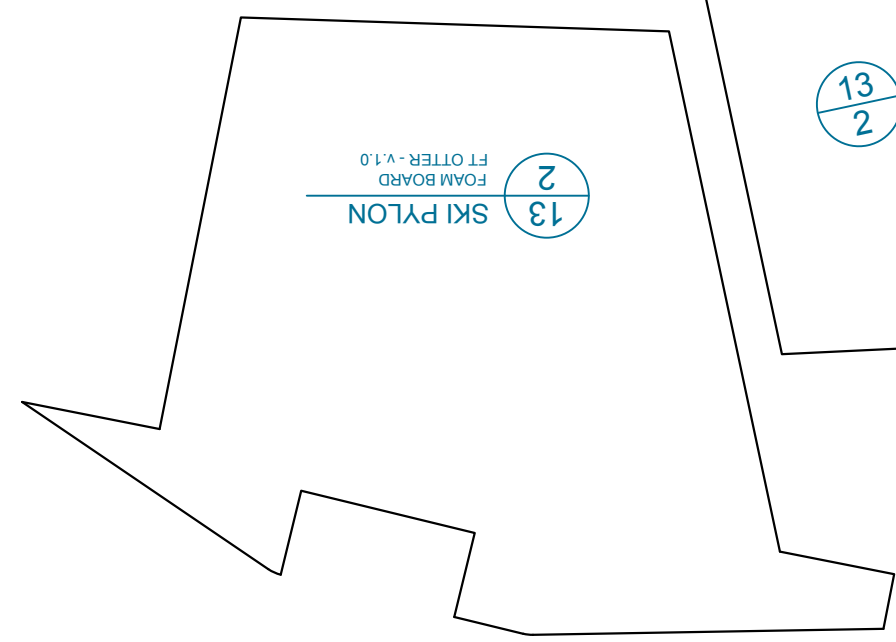
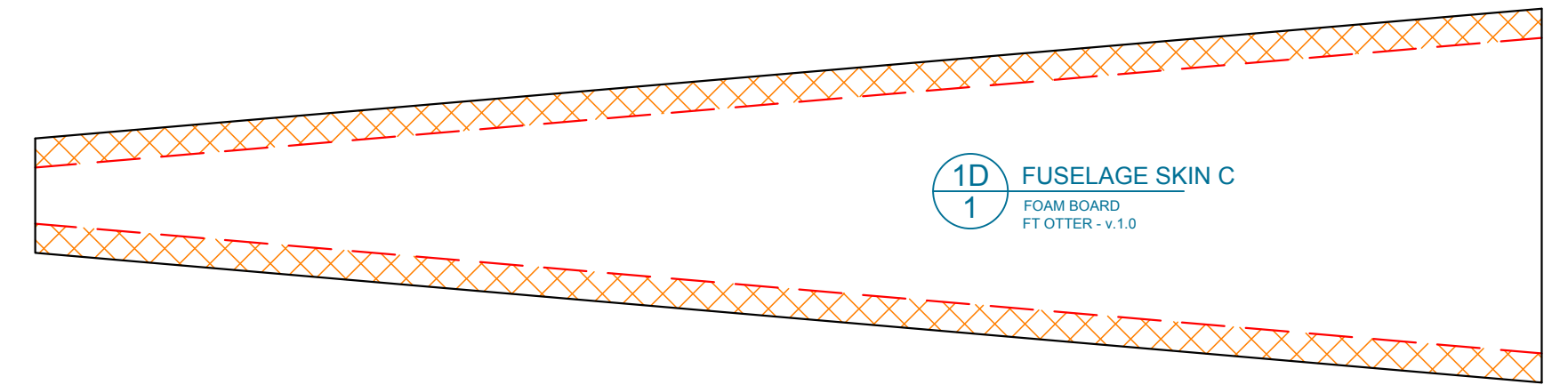
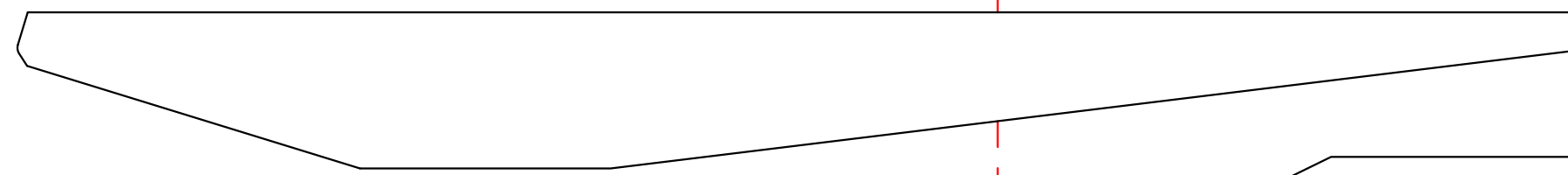
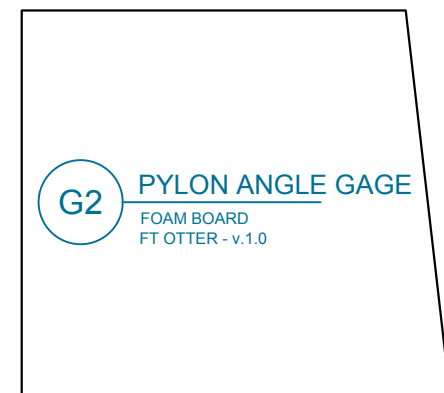
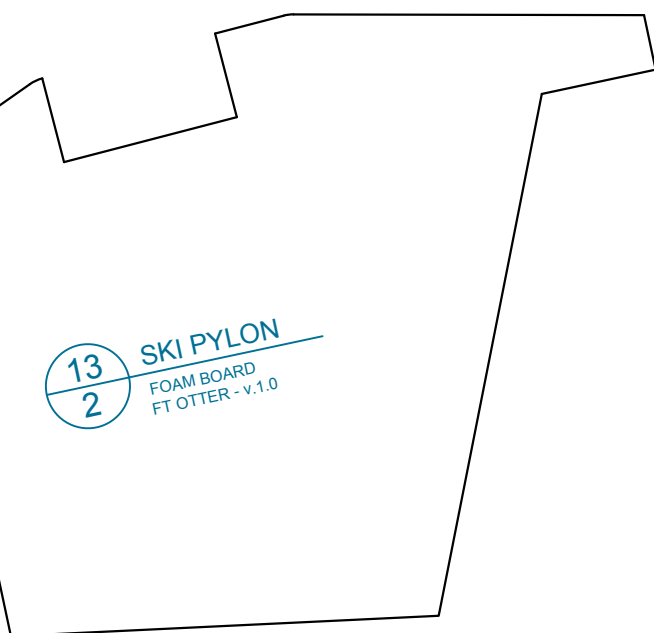
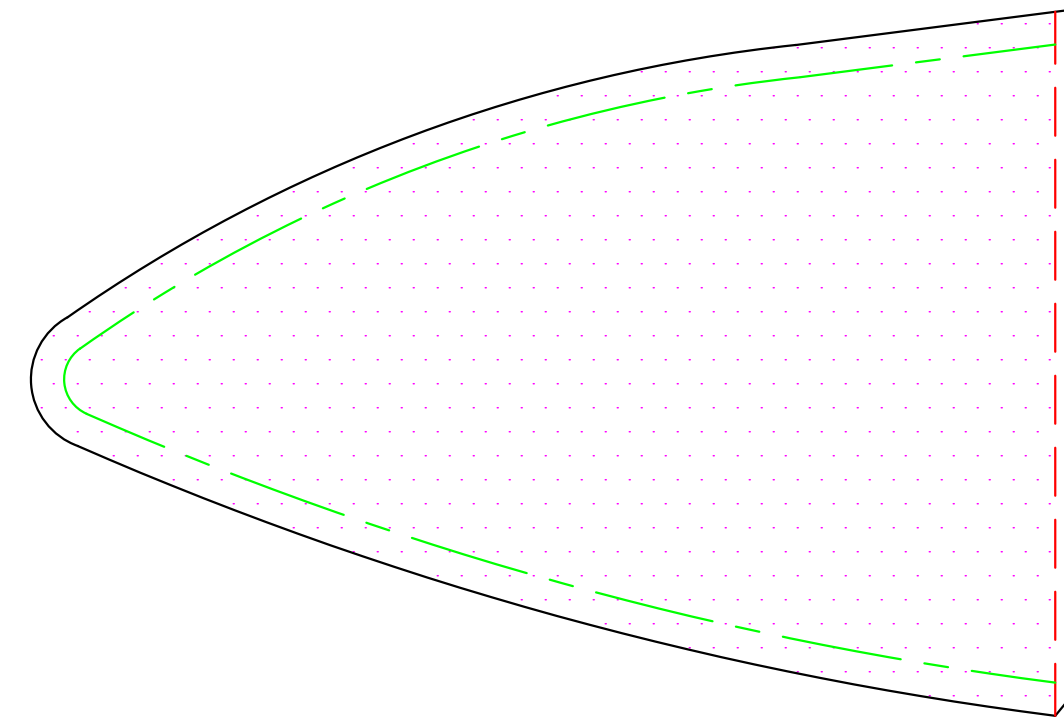
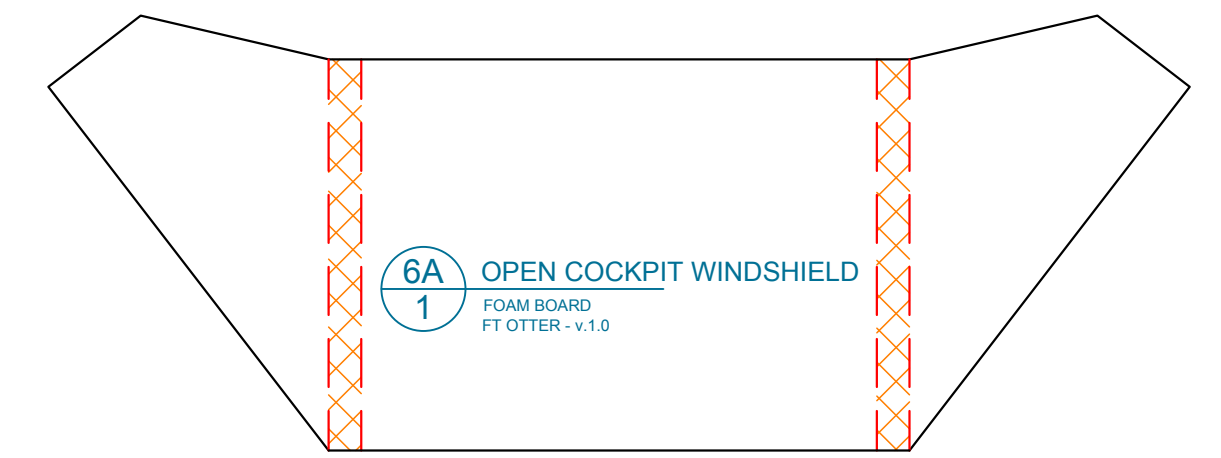
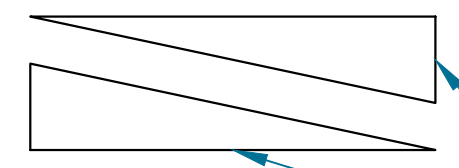
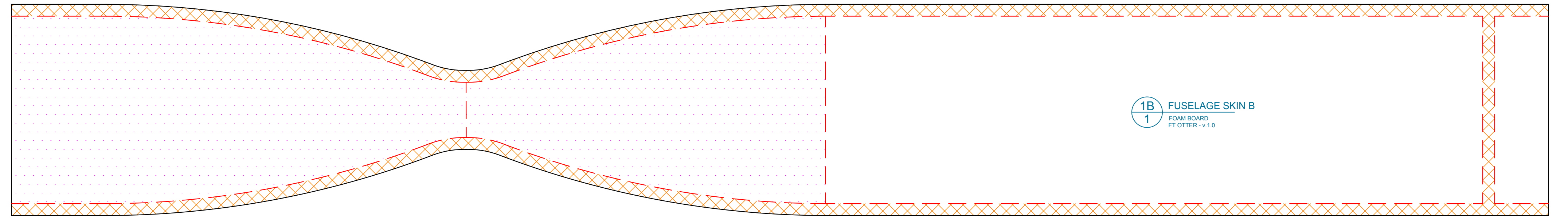
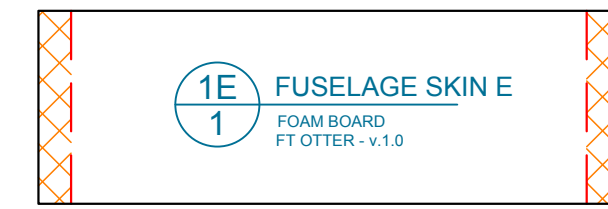
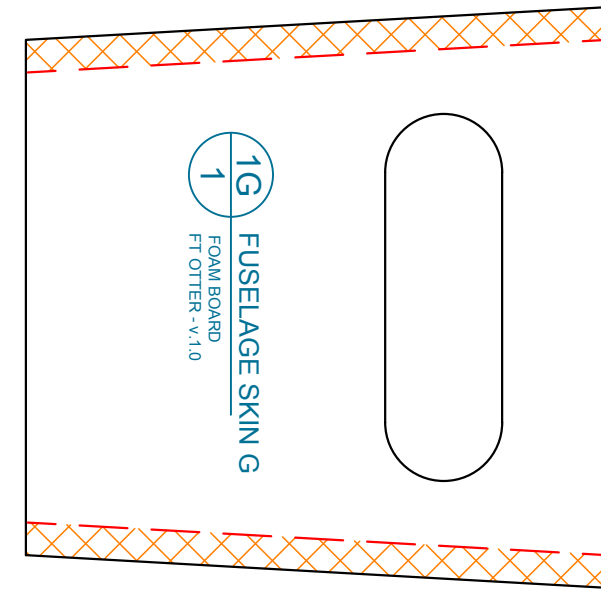
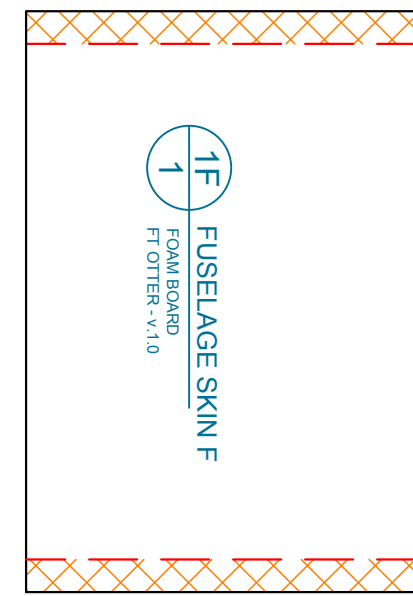

FT Otter

Designed By: Peter Stripol
Drawing By: Dan Sponholz

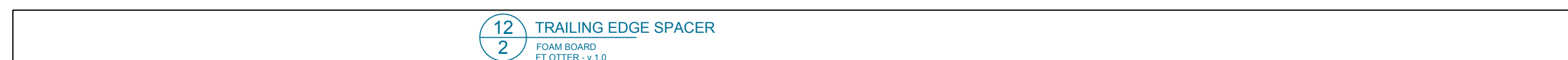
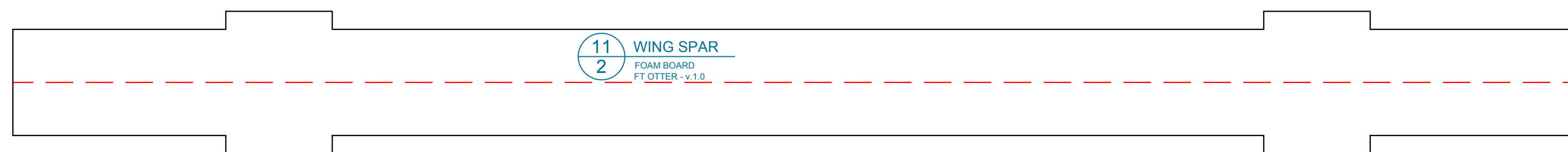
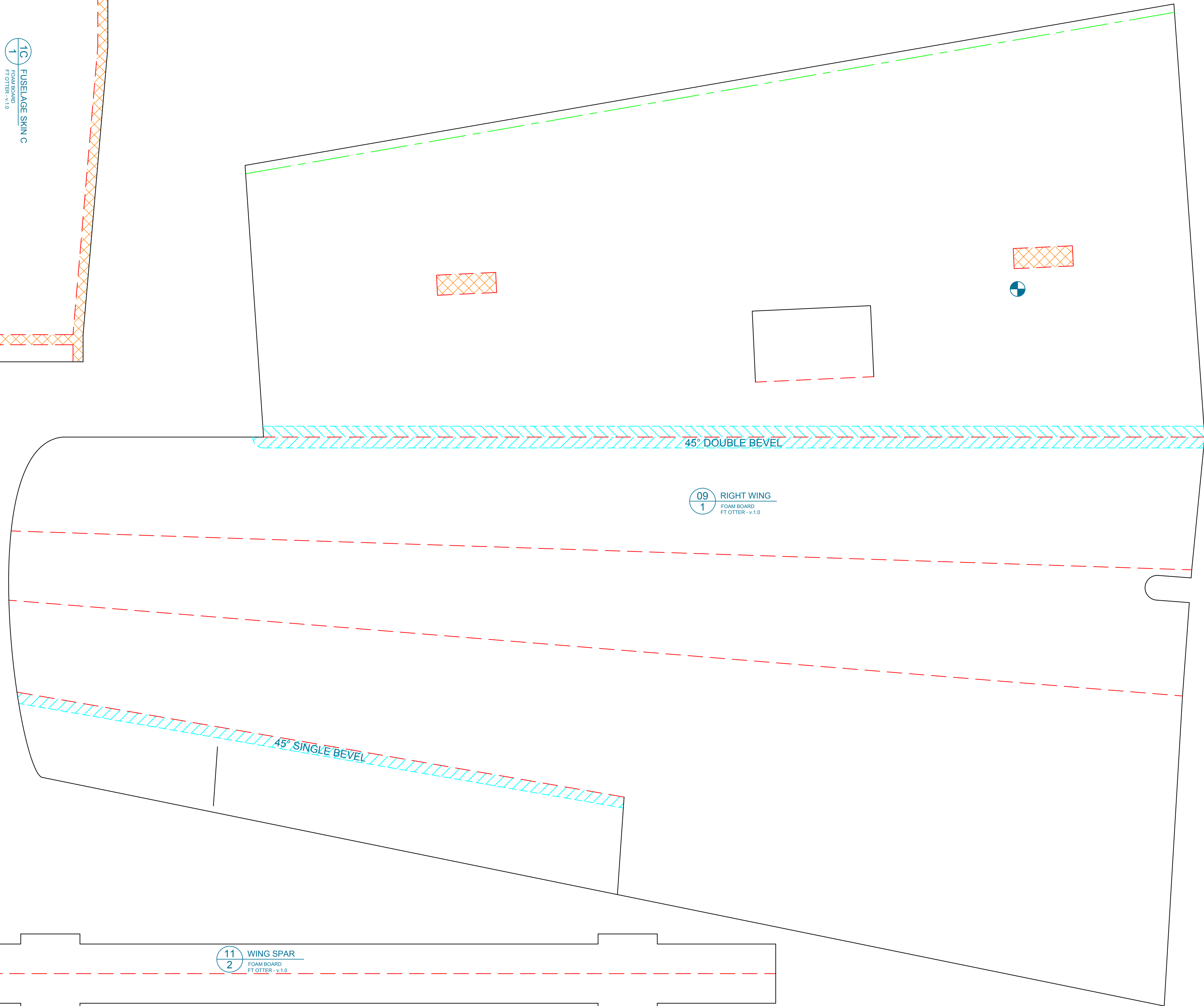
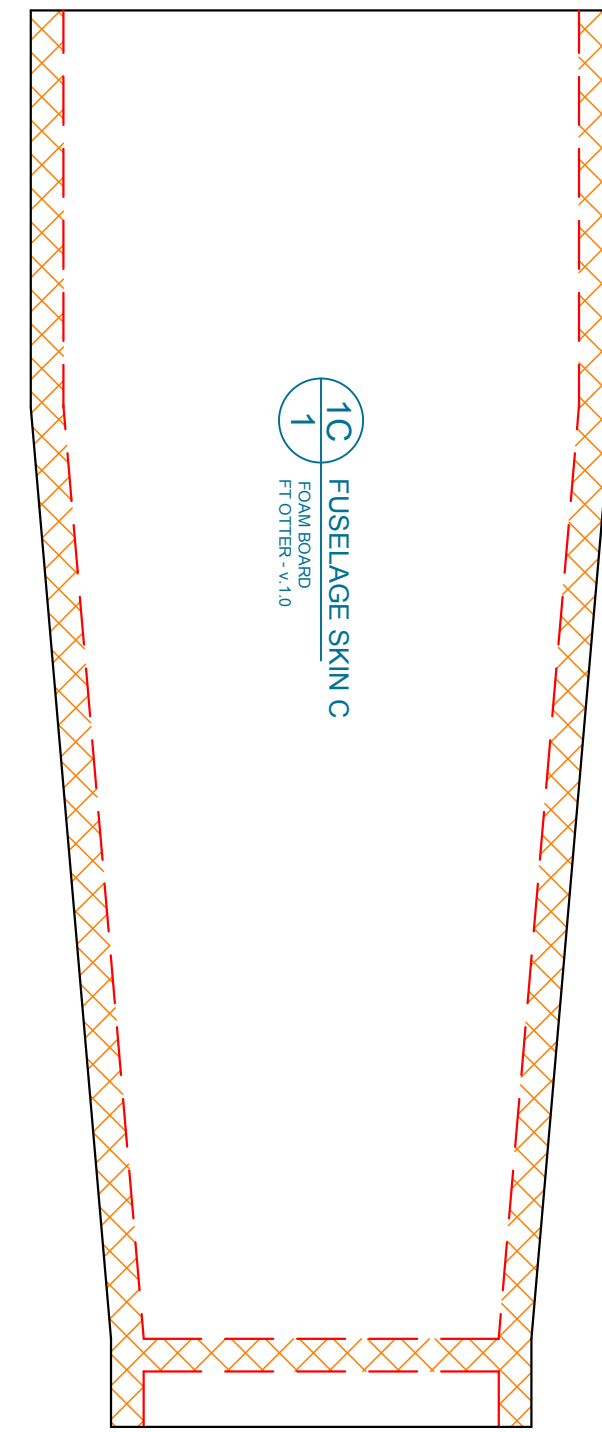
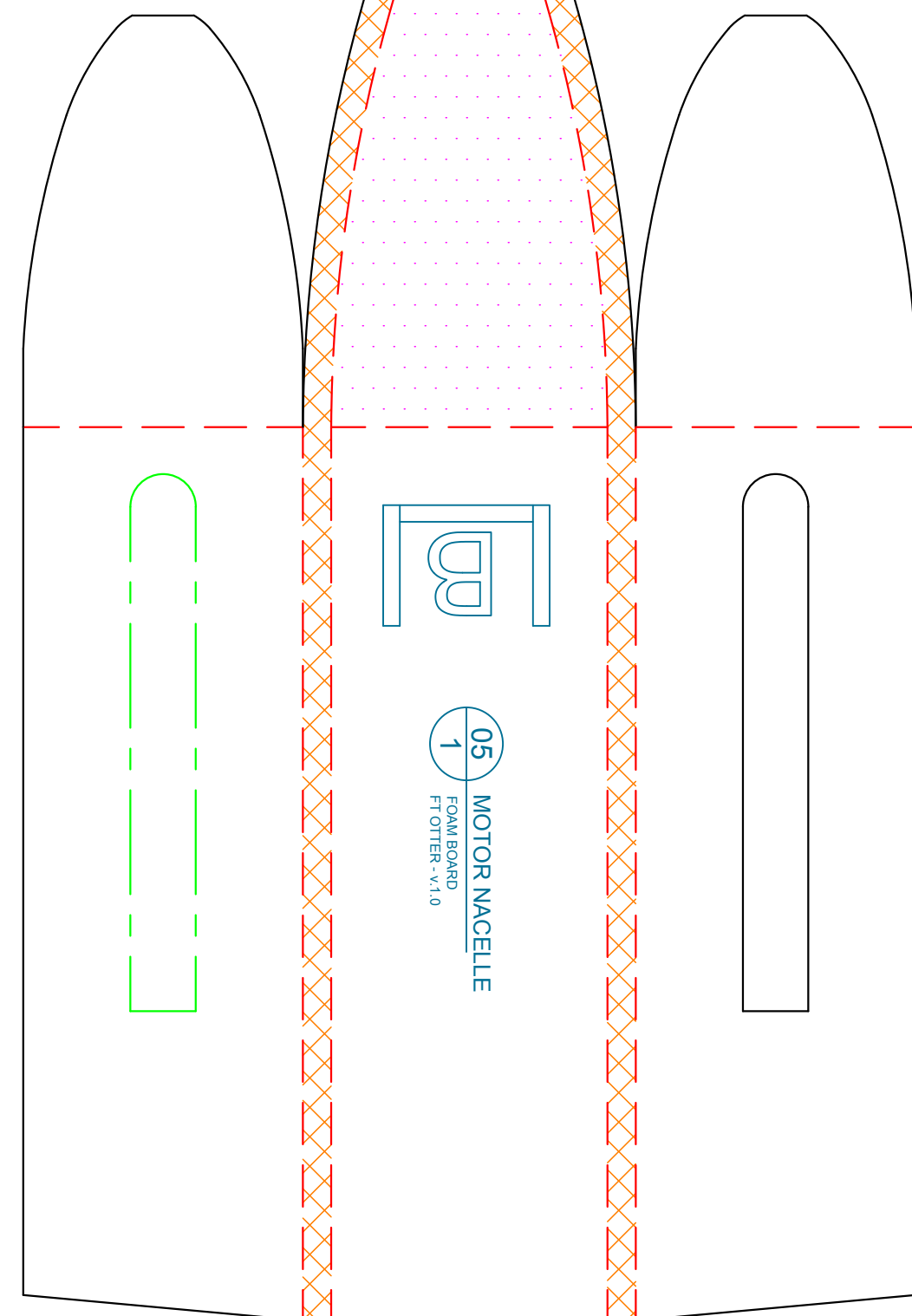
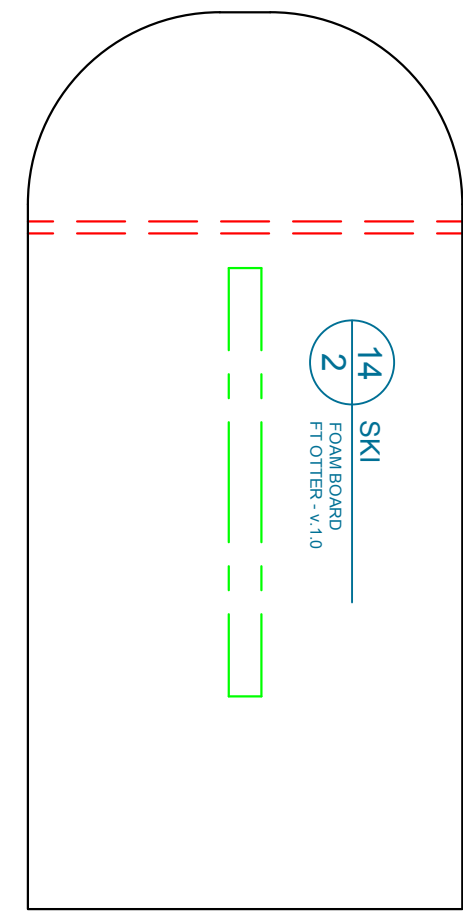
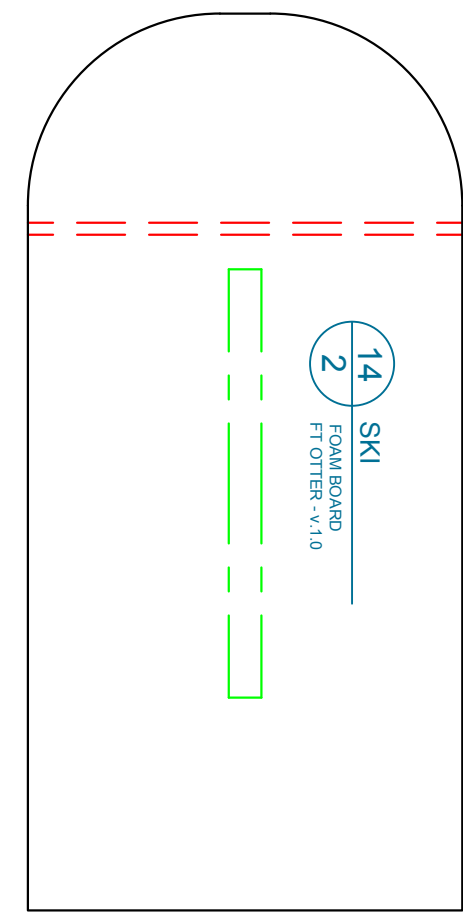

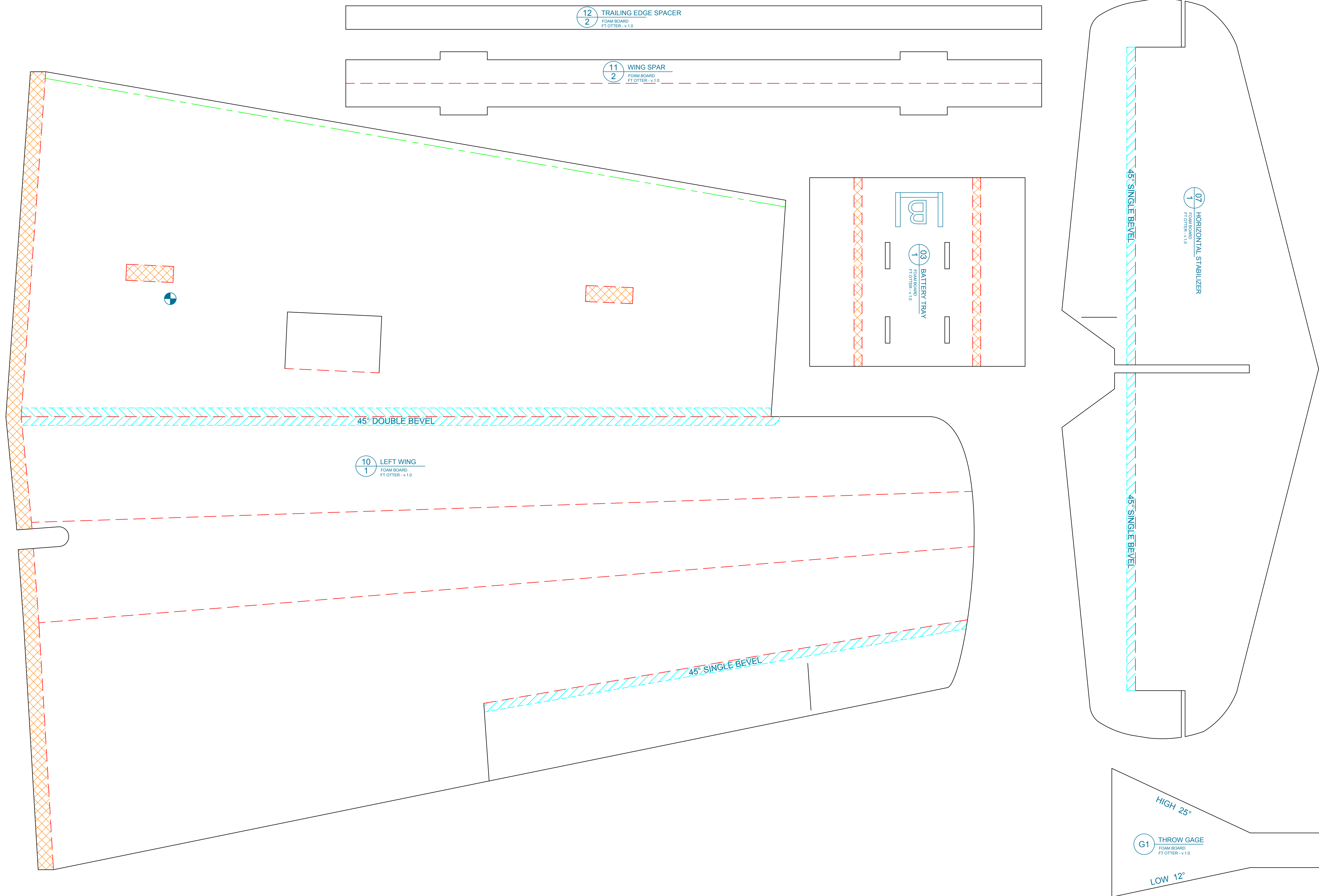

FT Otter

Designed By: Peter Stripol
Drawing By: Dan Sponholz

